

Installation Guide for Drip Edge

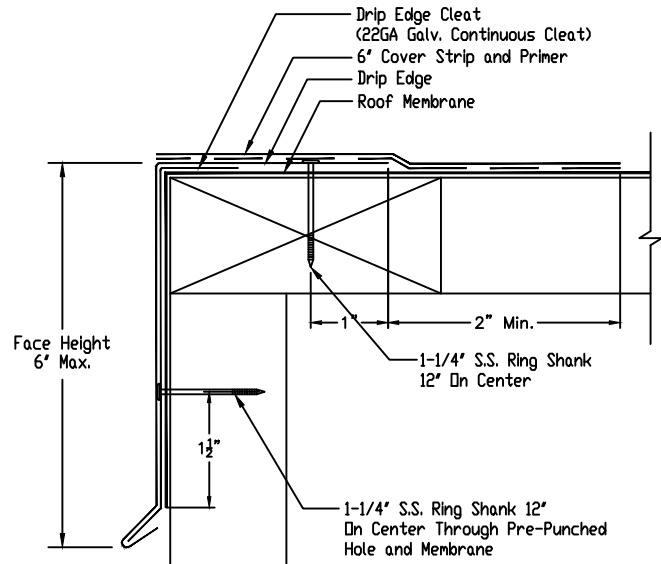

NOTES:

- #1 - Isolate all metal parts from ACQ treated wood or other galvanically incompatible material with appropriate membrane material.
- #2 - Appliance attachments, such as lightning rods, signs, or antennae that penetrate the water seal, induce a galvanic reaction, or otherwise compromise the effectiveness of the roof edge system, shall be eliminated or isolated to prevent problems per section 8.0 if ANSI/SPRI ES-1. Appliances should also be isolated from, or not attached to, the roof edge system. Consult the lightning protection system manufacturer for specific attachment instructions.

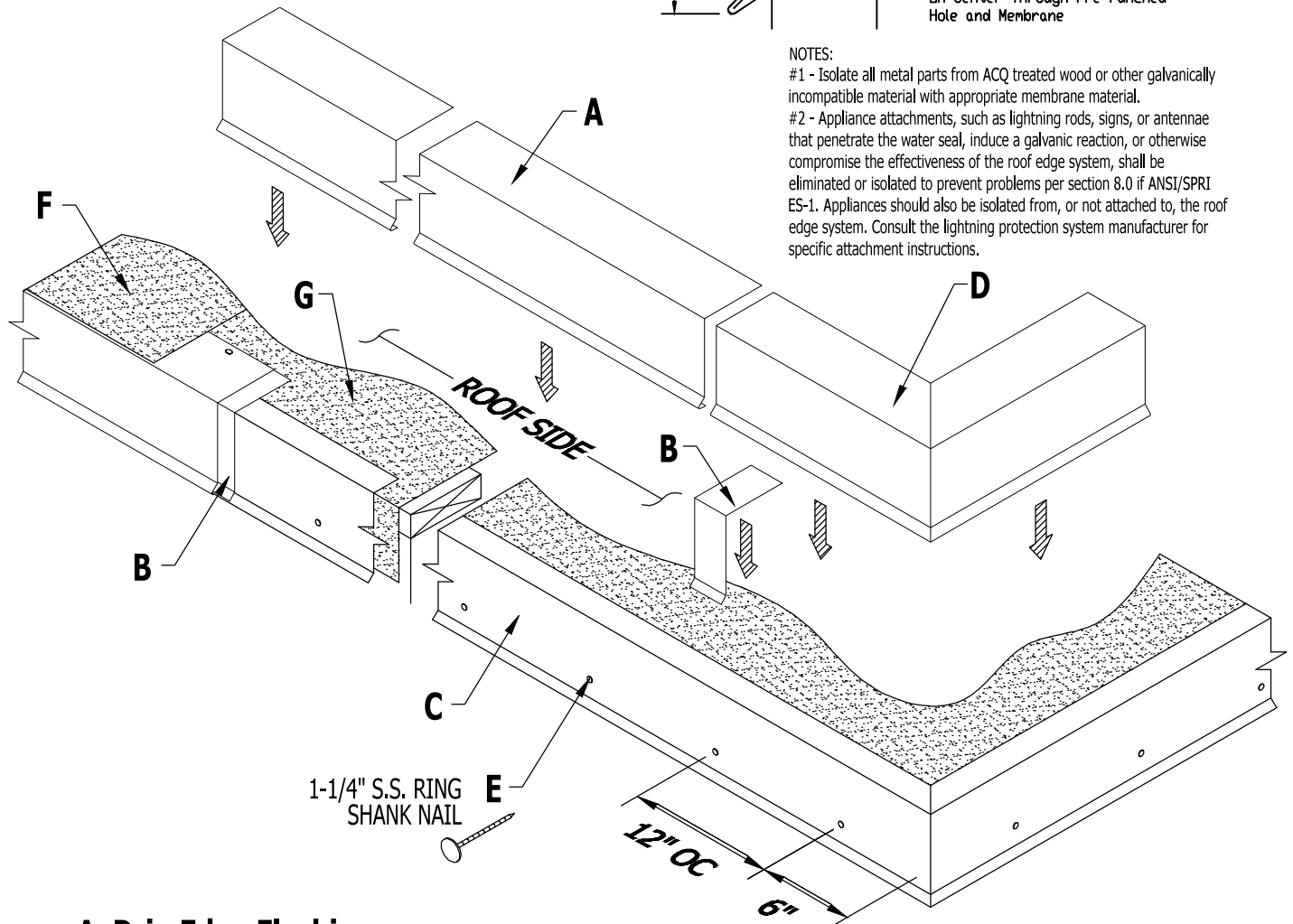

A. Drip Edge Flashing
10'-0" Std. Lengths

B. Drip Edge Splice Plate
6" Lengths

C. 22GA Galvanized Continuous Cleat
10'-0" Lengths

D. Drip Edge Miter
(Outside Corner Shown)

E. 1-1/4" S.S. Ring Shank Nail
at 12" o.c. (6" from ends)
(Included & Required)

F. 6" Cover Strip
(By Installer)

G. Approved Roofing Membrane
(By Installer)

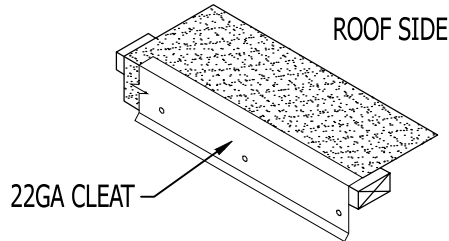

STEP 1: Installing 22GA Galvanized Cleat

Place the top lip of the Cleat squarely on the top edge of the roofing membrane and treated wood nailing plate. Press cleats securely in position and nail through the pre-punched holes with 1-1/4" S.S. Ring Shank Nails provided. For Miter application, fit into corner as required to maintain a continuous Cleat line. Then nail at a min. 6" in each direction from the corner or closer at special conditions.

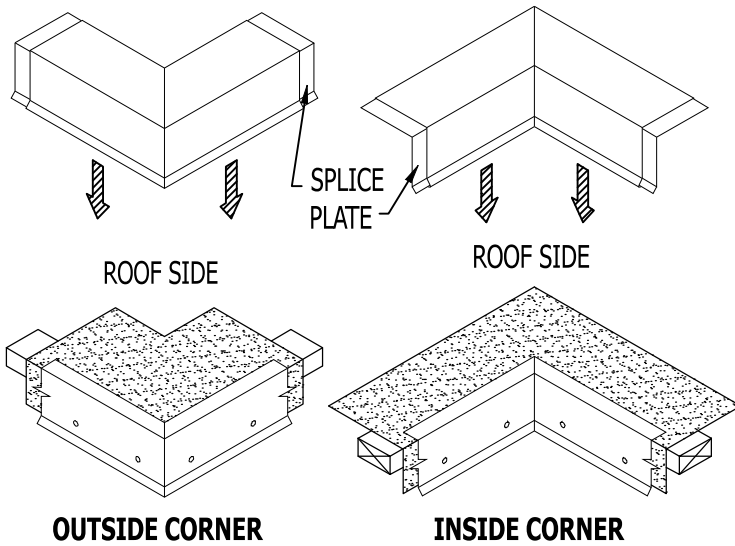

STEP 2: Drip Edge Miters

Locate the Miters and Splice Plates for the appropriate corners. Place a Splice Plate under each end of the Miter sections. Install the Miter by hooking the Drip Edge Miter onto the kick out of the Cleat, and rotate back onto the roof. Fasten with 1-1/4" S.S. Ring Shank nails provided at 12" on center maximum.

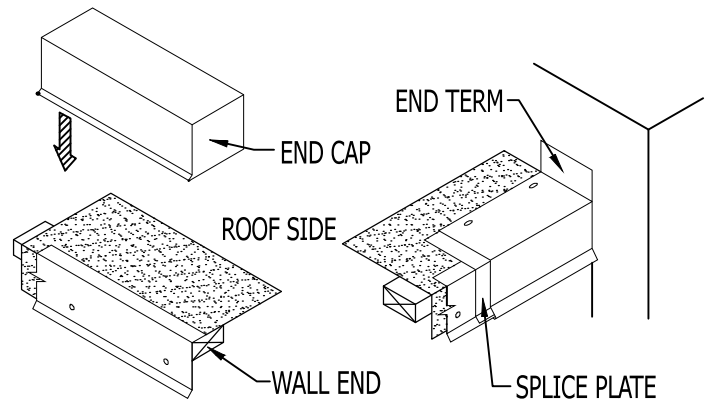

STEP 3: Installing Drip Edge End Caps & Terms

Install the Drip Edge End Caps and End Terms by hooking the drip of the Drip Edge End Cap or Term onto the kick out of the Cleat and rotate back onto the roof. Fasten with 1-1/4" S.S. Ring Shank Nails provided at 12" on center maximum.

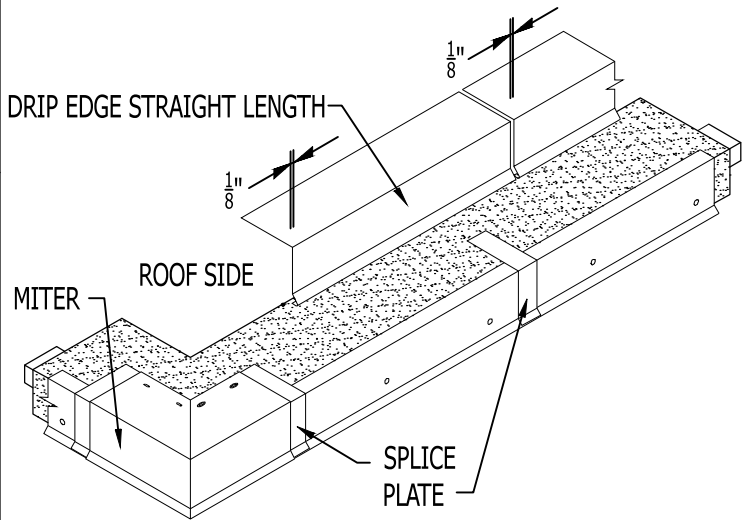

STEP 4: Installing Drip Edge Straight Lengths

Place a Splice Plate in the opposite end of the installed Miter or End Cap. Install the Drip Edge by hooking the drip on to the kick out of the Cleat and rotate back onto the roof. Fasten with 1-1/4" S.S. Ring Shank Nails provided at 12" on center maximum. **Allow 1/8" Gap between Drip Edge lengths for thermal expansion.** Consider lengths of all straight pieces prior to cutting to avoid creating relatively short sections adjacent to one another.

Note: There should be a Splice Plate at every joint.

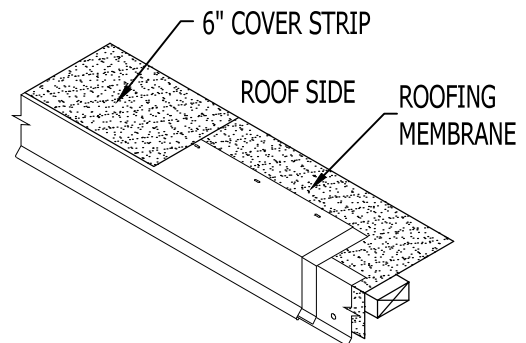

STEP 5: Installing Approved Roofing Membrane

Install 6" Cover Strip per roofing manufacturer's instructions.