

DMC 200S - OPEN FRAMING

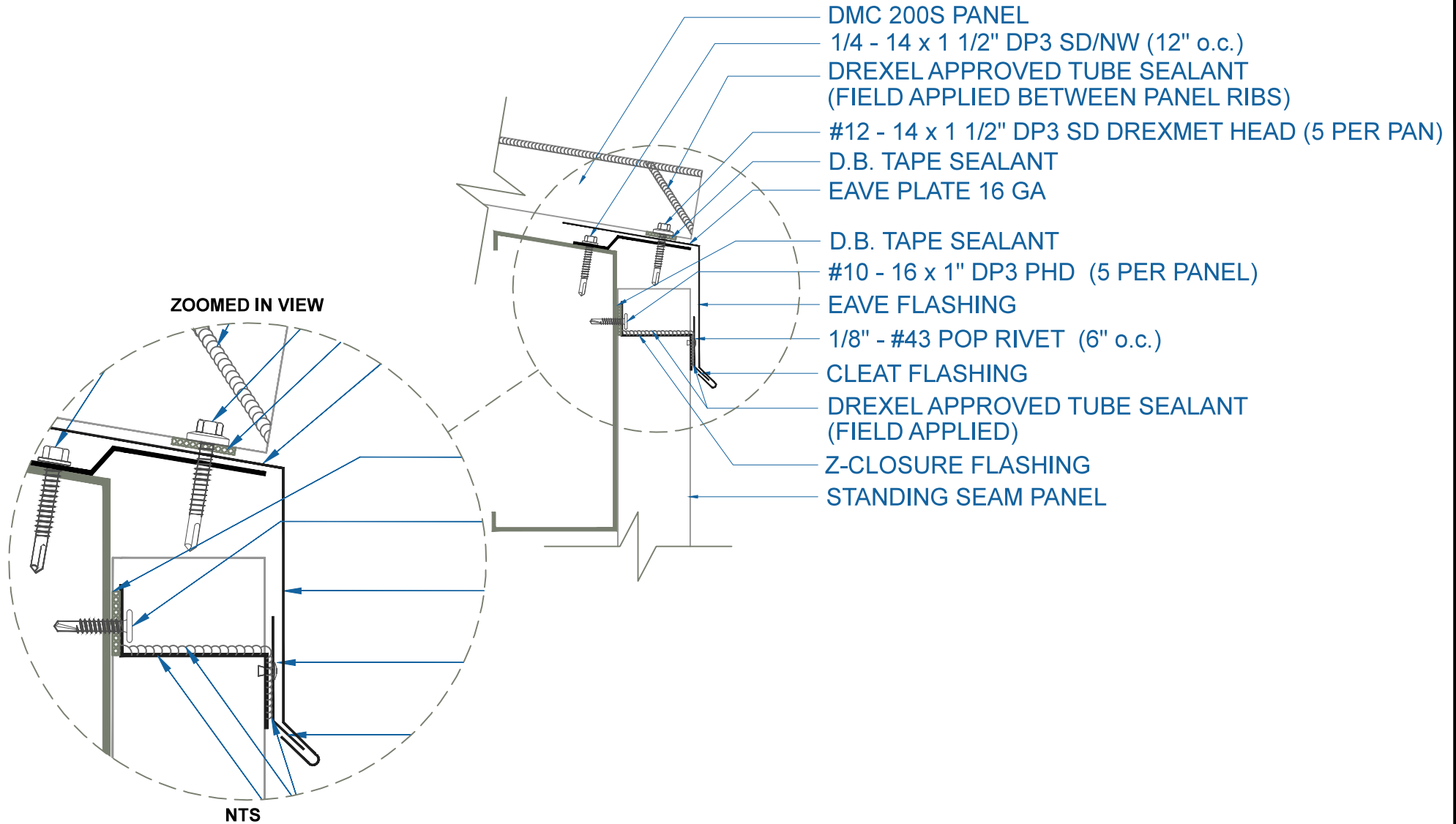

EAVE w/STANDING SEAM PANEL

SCALE: 3" = 1'-0"

EFFECTIVE DATE: 01-18-13
SUBJECT TO CHANGE WITHOUT NOTICE

DrexelMetals
Roofing Systems + Custom Fabrication

